



## STANDARD 14.5.3

---

### FIRE HYDRANTS

*The information contained in this standard is provided solely for the convenience of the reader and was being enforced by the Ventura County Fire Protection District at the time of its publication. The District reserves the right to make changes and improvements to this standard as and when required by law, or otherwise, at any time. (The District's current standards will be posted and made available for downloading by the public at the following web site: <http://fire.countyofventura.org>.)*

*Please note that the District assumes no liability for any damages incurred directly or indirectly as a result of any errors, omissions, or discrepancies between this standard and any applicable law. It is the sole responsibility of the person or persons conducting any work pursuant to this standard to ensure their work complies with any and all applicable codes, ordinances, and regulations.*

#### CHAPTER 1 ADMINISTRATION

**1.1 Scope.** This standard applies to the selection, placement and required flow of fire hydrants in conjunction with the Ventura County Fire Code (VCFC), the Ventura County Water Works Manual and other applicable codes. For private drafting hydrants, see Fire Prevention Standards 14.5.4, 14.5.5 and 14.6.2.

**1.2 Purpose.** This standard is prepared for the use and guidance of those charged with providing fire hydrants. It provides basic requirements for fire hydrants, how they are located and installation information.

**1.3 Responsibility.** All individuals and companies who intend to engage in the installation or alteration of fire hydrants are subject to the requirements of this standard.

#### CHAPTER 2 DEFINITIONS

**2.1 General.** The following words and terms shall, for the purposes of this standard and permit requirements of the VCFC, have the meanings shown herein.

**2.2 Access Point.** An approved access is required for all new buildings and shall reach to a point within 150 feet of all exterior areas of each building.

**2.3 Existing Parcels.** Parcels that were legally divided prior October 1, 1980.

**2.4 Occupancy Type.** The purpose for which a building, or portion thereof, is used or intended to be used.

**2.5 Private On-site Hydrant.** Fire hydrants that are located within the property lines and are privately owned and maintained.

**2.6 Public On-site Hydrant.** Fire hydrants that are located within easements on the property and are publicly owned and maintained.

**2.7 Single-Family Dwelling (SFD).** One and two-family dwellings, including attached or detached private garages.

**2.8 System-Side Hydrant (or Yard Hydrant).** Privately owned fire hydrants connected to underground piping between the Fire Department Connection (FDC) and the automatic fire sprinkler system. The use of these hydrants requires approval of the Fire Prevention Bureau. (See Fire Prevention Standard 14.7.2 for details)

**2.9 Type of Construction.** Determined in accordance with Chapter 6 of the California Building Code.

**2.10 Ventura County Fire Code (VCFC).** The specified portions of the California Building Standards Codes known as California Code of Regulations, Title 24, Part 9, "California Fire Code (CFC)" as adopted by the State Fire Marshal (SFM) and; portions of The International Fire Code (IFC), 2009 Edition referenced by the California Building Standards Code and not adopted or modified by the SFM and; the VCFPD amendments contained in Ordinance 27 to the above-referenced codes.

**2.11 Water Purveyor.** A public utility, a mutual water company, a governmental body, or other entity, owning and operating a water system and holding a valid permit from the State or County Health Department to purvey water. Ref: Ventura County Water Works Manual

### CHAPTER 3 GENERAL REQUIREMENTS

**3.1 Hydrant Location Plans.** Hydrant location plans shall be submitted to the Fire Prevention Bureau prior to installation of hydrants. Do not place the proposed hydrants on the site plan. The Fire Prevention Bureau will place the proposed hydrants based on the criteria discussed in this standard. (See Chapters 8 and 9 of this standard for details on submitting plans)

**3.2 Installation.** Fire hydrants shall be provided prior to and during the time of construction. Hydrants shall be accessible and visible from a required access road.

**3.3 Concrete Pad.** A concrete pad shall be provided around each hydrant. The pad shall extend a minimum of 18 inches from the hydrant in all directions. (See Exhibit B)

**3.4 Color.** Hydrants shall be painted yellow.

**3.5 Outlet Threads.** All hydrant outlets shall be National Standard Thread (NST).

**3.6 Reflective Pavement Markers.** Prior to occupancy of any structure, blue reflective hydrant location markers shall be placed on the access road in accordance with Fire District standards. If the final asphalt cap is not in place at the time final occupancy is desired, the hydrants markers shall be installed and replaced when the final asphalt cap is completed. (See Exhibit C)

**3.7 Required Fire Flow.** The required fire flow is based on building size (sqft), use/occupancy type and type of construction. The VCFC allows a reduction for fire sprinklers when approved. (See Fire Prevention Standards 14.5.4 and 14.5.5 for fire flow requirements.)

**3.8 Number of Hydrants.** The number of hydrants required is based on use/occupancy type, required fire flow, along with distance and access considerations. (See VCFC Appendix C)

**3.9 Minimum Flow per Hydrant.** A minimum flow per hydrant shall be provided as follows:

(1) Single-family dwellings – 1,000 gpm

(2) Required fire flows less than or equal to 3,000 gpm (flowing one hydrant) – 1,250 gpm

- (3) Required fire flows greater than 3,000 gpm (flowing one hydrant) – 1,500 gpm
- (4) When two or more hydrants are flowing, the minimum flow from each hydrant shall be 1,000 gpm

**3.10 Changes/Relocations.** Hydrants shall be installed at the locations approved by the Fire Prevention Bureau. Any changes or relocation of hydrants from the approved hydrant location plan shall be approved by the Fire Prevention Bureau prior to installation or relocation.

## CHAPTER 4 UNDERGROUND SUPPLY PIPING

**4.1 General.** Plans and specifications shall be submitted to the Fire Prevention Bureau as indicated in this section and elsewhere in this standard.

**4.1.1 Public On-Site Hydrants.** Underground plans shall be submitted directly to the water purveyor for plan check and approval. Final inspection will be conducted by the water purveyor. Some Public Works Departments require the Fire Prevention Bureau to sign final water improvement plans or mylars, prior to issuance of a permit to construct the improvements. You will need to contact the Fire Prevention Bureau at (805) 389-9738 to schedule an appointment to have the final plans/mylars signed. You will need to bring a copy of the approved hydrant location plan to the appointment.

**4.1.2 Private On-Site and System-Side Hydrants.** Engineered underground plans shall be submitted directly to the Fire Prevention Bureau for plan check and approval. Once the plans are approved, the contractor will install the underground and hydrants. All underground piping shall be inspected by the Fire Prevention Bureau prior to covering. The Fire Prevention Bureau must also witness a hydrostatic test and flush. (See Fire Prevention Standard 14.7.2)

## CHAPTER 5 SINGLE-FAMILY DWELLINGS

**5.1 General.** Hydrants required for projects involving single-family dwellings shall be in accordance with this chapter and VCFC Appendix C. When the site is not served by a purveyor or the purveyor is unable to supply the required fire flow, fire sprinklers and a water storage tank will be required. Restrictions apply, see Fire Prevention Standard 14.5.4 and VCFC Appendix B

**5.2 Distance to Hydrant.** The maximum distance from any structure's access point to a hydrant shall not exceed 250 feet (500 foot spacing), as measured along the required access.

**Exception:** *The following exceptions apply to existing parcels only (500 gpm required).*

- (1) *Up to 500 feet from the access point to a hydrant with required fire flow is permitted.*
- (2) *Up to 1,000 feet from the access point to a hydrant with required fire flow is permitted if the hydrant is within 250 feet of the driveway entrance and fire sprinklers are installed per Fire Prevention Standard 14.7.1.*

**5.2.1 Excessive Distance to Water Supply.** For a single-family dwelling located more than 1,000 feet from the nearest water supply capable of providing the fire flow, use of a water storage tank and fire sprinklers may be allowed when approved by the Fire Prevention Bureau and water purveyor (if applicable). Restrictions apply, see Fire Prevention Standard 14.5.4 and VCFC Appendix B

**5.3 Hydrant Size and Type.** All hydrants shall be a 6 inch wet barrel hydrant with one (1) 4 inch and one (1) 2-1/2 inch outlets.

**Exception:** A wharf-head hydrant with a 4 inch riser and 2-1/2 inch outlet will be acceptable in the following instances:

- (1) For on-site protection of one or two single-family dwellings when only 500 gpm fire flow is required.
- (2) For remote residential projects with tanks, when approved by the Fire Prevention Bureau. (See Fire Prevention Standard 14.5.4)

## CHAPTER 6 MULTI-FAMILY, COMMERCIAL AND INDUSTRIAL PROJECTS

**6.1 General.** Hydrants required for multi-family, commercial or industrial projects shall be in accordance with this chapter and VCFC Appendix C. When the site is not served by a purveyor or the purveyor is unable to supply the required fire flow, fire sprinklers and a water storage tank will be required. Restrictions apply, see Fire Prevention Standard 14.5.5 and VCFC Appendix B

**6.2 Distance to Hydrant.** The maximum distance from any structure's access point to a hydrant shall be in accordance with VCFC Appendix C, as measured along the required access.

**6.3 Hydrant Size and Type.** All hydrants shall be a 6 inch wet barrel hydrant. The number and size of outlets shall be as based on required fire flow as follows:

- (1) Fire flow up to 3,000 gpm – One 4 inch and two 2-1/2 inch outlets
- (2) Fire flow over 3,000 gpm – Two 4 inch and one 2-1/2 inch outlets

## CHAPTER 7 SCHOOLS

**7.1 Public Schools.** California Fire Code (CFC) Appendix CC shall be used to determine distance/spacing and number of hydrants. The State Fire Marshal (SFM) requires the Division of State Architect (DSA) to request water and access requirements and approval from the local jurisdiction. (See Fire Prevention Standard 14.6.10 for additional details)

**7.2 Private Schools.** Private schools shall comply with all the requirements for commercial buildings. Local requirements are applicable to private schools.

## CHAPTER 8 PLANS SUBMITTAL

**8.1 General.** A hydrant location plan check is required for all projects where new buildings or additions to buildings are proposed and the project is not exempt from providing fire flow. Plans and specifications shall be submitted to VCFPD, Fire Prevention Bureau as indicated elsewhere in this document.

**8.2 Building Permits.** Obtain any applicable permits from the appropriate Building & Safety Department, Public Works Department or water purveyor.

**8.3 Plans and Specifications Submittal.** Plans and specifications shall be submitted for review and approval prior to building permit application for new structures. In addition to the information required by the applicable standard, the submittal shall include the information specified herein. Once approved, a copy of the approved plan shall be maintained on the premises.

**8.4 Submittal Requirements.** Submit a minimum of three sets of plans, Fire Prevention Bureau incoming transmittal form and the appropriate fees to the Ventura County Fire Prevention Bureau located at 165 Durley Avenue, Camarillo CA 93010. Fire Prevention Counter hours are Monday through Friday, 8:00 a.m. to 5:00 p.m.

**8.5 Fees.** Appropriate fees can be found in the Ventura County Fire Protection District's Fee Schedule at <http://fire.countyofventura.org> or by calling the Fire Prevention Counter at (805)389-9738. Fees can be paid by check/money order, Visa or MasterCard. Plan Check fees include the original plan check and one re-check. Please ensure that all corrections are made prior to re-submittal to avoid additional fees. All fees shall be paid at the time of plan submittal.

**8.6 Plans Approval.** Plans will be checked and if approved, will be stamped “**Acceptable**”, signed and dated. The Fire Department will retain one set.

**8.7 Case Number.** The Fire Department has instituted the use of a “**Case Number**” for tracking all projects submitted for review. To provide faster customer service, please refer to your Case Number when contacting this Department. Your Case Number will also be listed on the Fire Department approved plans.

**8.8 Field Changes.** Excessive field changes may require re-submittal of plans along with additional plan check fees.

## CHAPTER 9 PLAN SPECIFICATIONS

**9.1 Specifications.** Site/Plot plans shall be drawn with care by a trained person.

**9.2 Size and Scale.** Plans shall be drawn on a minimum of 24”x36” paper and shall be drawn to an indicated scale of not less than 1 inch = 10 feet.

**9.3 Plans.** The following items shall be included in all site/plot plans:

- (1) Name of owner and/or occupant
- (2) Location of project, including street number, street name and city
- (3) Plot plan showing roads and driveways, parking lots, gates and all structures existing and proposed
- (4) Existing hydrants located within 500 feet. Indicate size of hydrant(s), number and size of outlets on each hydrant (i.e. 6 inch wet barrel with one 4 inch and two 2-1/2 inch outlets). Do not show the proposed hydrants on the site plan. That is the purpose of the plan check and Fire Prevention personnel will place the proposed hydrants.

## EXHIBIT A

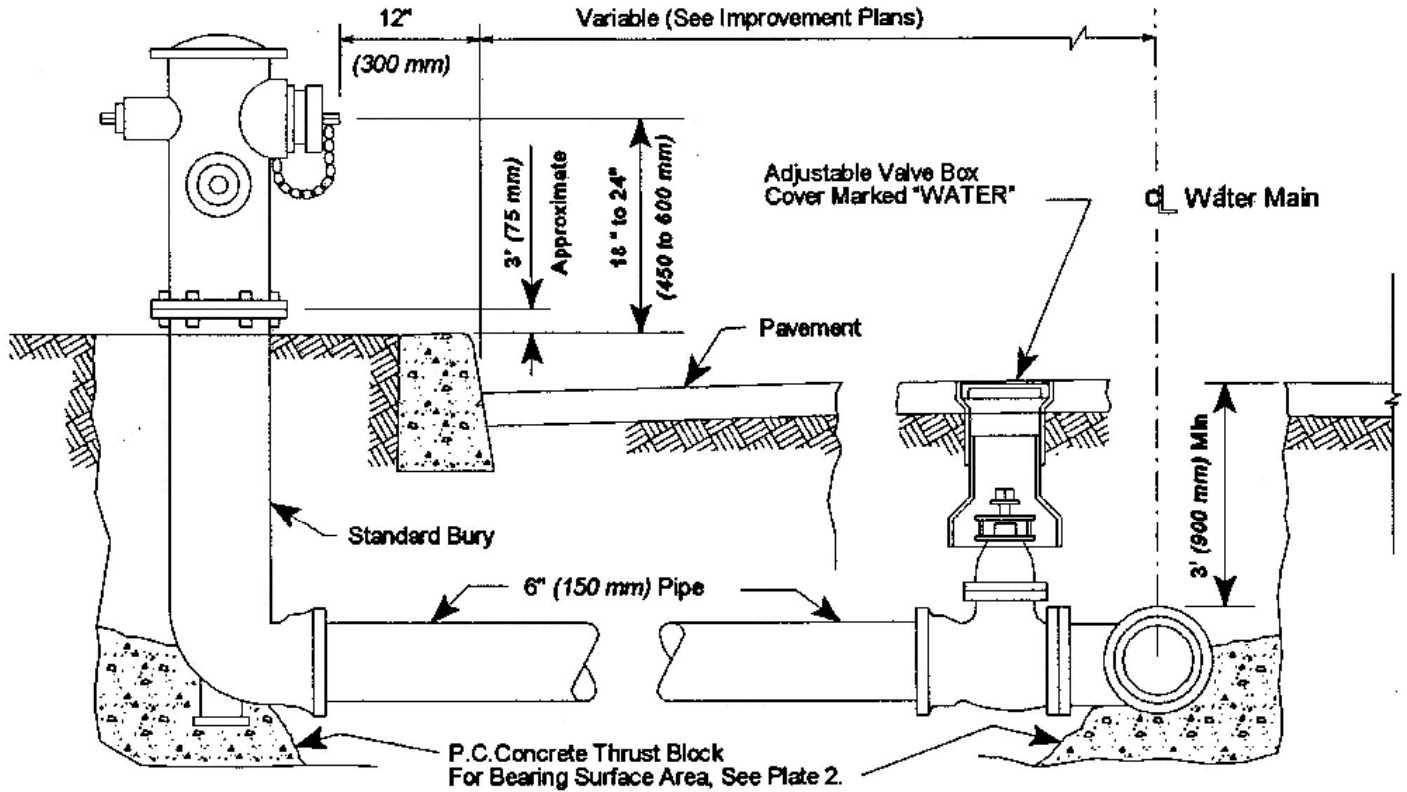

Ref: Ventura County Water Works Manual

### Notes

1. All materials and installation shall conform to the applicable sections of the Ventura County Water Works Manual (VCWWM) or applicable City Water Works Manual.
2. When installation is adjacent to roads without curbs, fire hydrants shall be located within the road right-of-way, three feet clear of the property line. An eight foot wide clear, level access to the fire hydrant across the roadside ditch shall be provided by the installation of a properly sized culvert and fill. A driveway adjacent to the fire hydrant may be used to provide the required access.
3. Fire hydrants shall not be closer than three feet from driveways, street trees, lighting standards, signs or other obstructions.

## EXHIBIT B

### SUGGESTED HYDRANT LOCATIONS

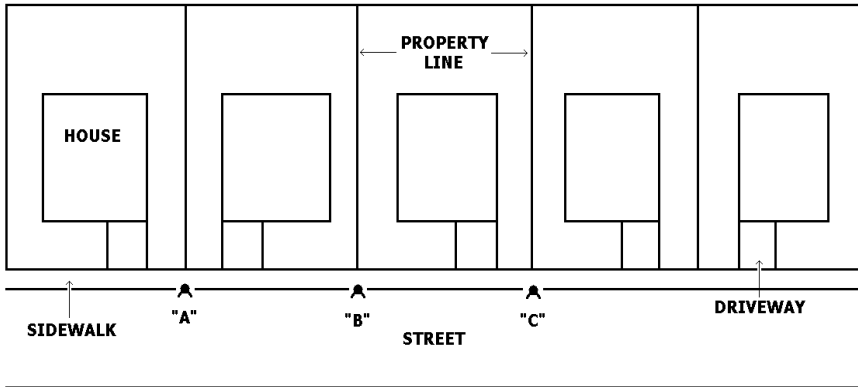

"A" is preferred      "B" is least preferred      "C" is second choice

### FIRE HYDRANTS

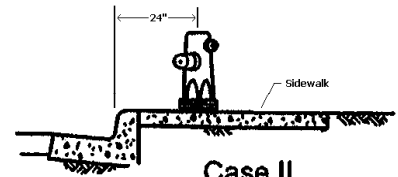
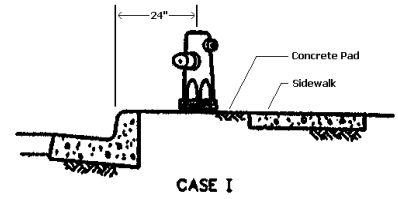

(Consult local authority for sidewalk extension at hydrant)

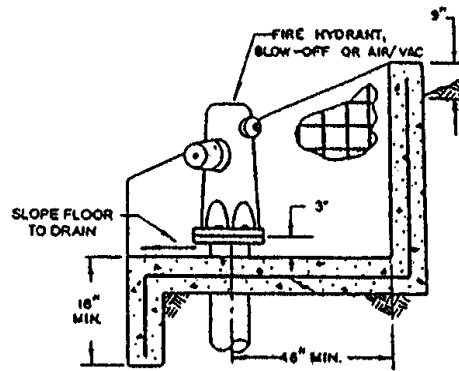
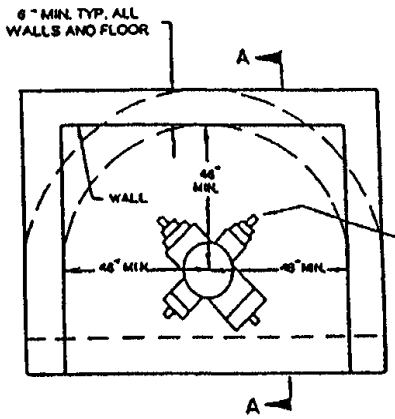
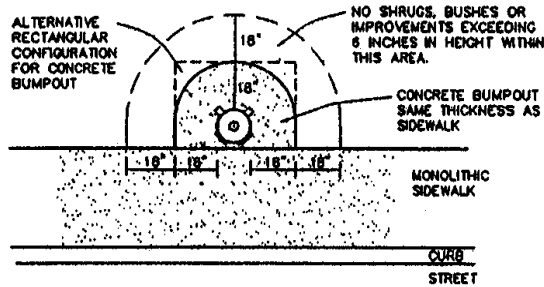
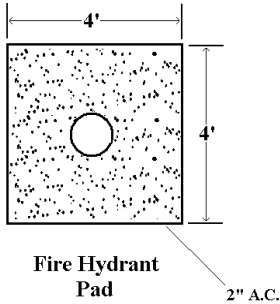
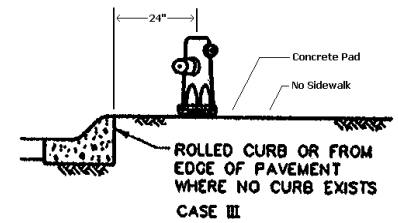

(To be used where ground slopes exceeds 30% or as required)

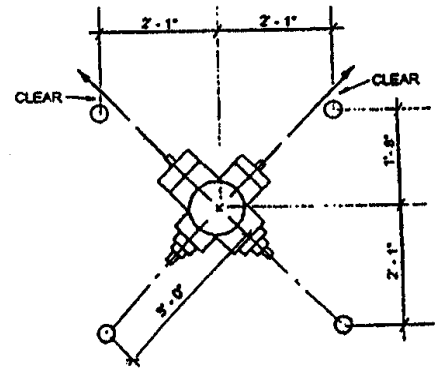

### Notes:

- Hydrants shall have a concrete pad per Section 3.3 of this standard
- Consult local Building and Safety Department for permit requirements for walls
- Guard posts may be required and shall be installed per Fire Prevention Standard 14.4.2

# EXHIBIT C

## TYPICAL HYDRANT MARKER LOCATIONS

Figure 1  
TWO LANE STREET

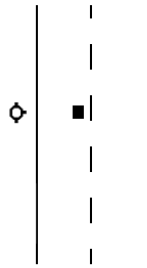

Figure 2  
MULTI-LANE STREET

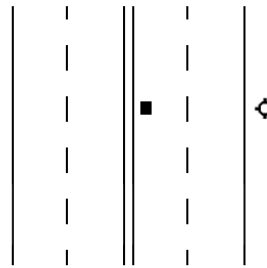

Figure 3  
TWO LANE STREET  
AT INTERSECTION

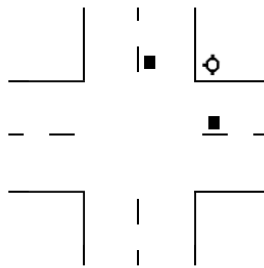

Figure 4  
FOUR LANE STREET WITH TURN LANE  
AT INTERSECTION

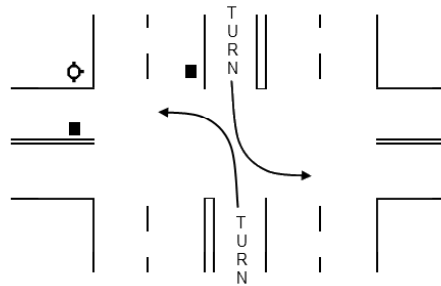

Figure 5  
MULTI-LANE STREET WITH  
TURN LANE

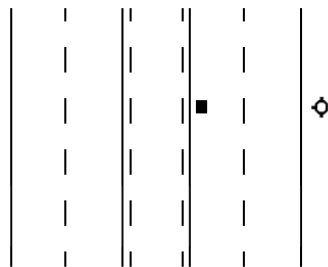
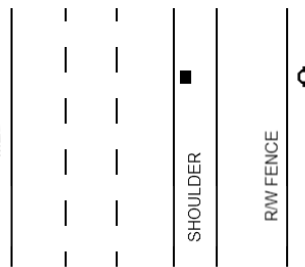
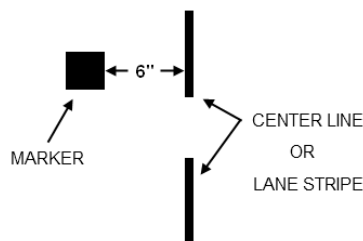

Figure 6  
FREEWAYS AND EXPRESSWAYS



## HYDRANT MARKER DETAIL





## **EXHIBIT D**

### **GENERAL GUIDELINES FOR FIRE HYDRANT PLACEMENT**

*Also see Exhibit B*

- Start at the entrance (s) to the project under review.
- Use existing hydrants if within the allowable distance based upon the type of project. (Existing hydrants may need to be upgraded) If not sure about existing hydrants, do a site inspection first.
- Flag lots may present a problem. Try not to place on-site unless over 300-400 feet. Place at the driveway entrance from the street and then base your adjacent hydrant spacing from there.
- If there is no on-site access required from the street, measure from the closest point on the street (nearest the structure) to the hydrant.
- Do not place along sharp bends in access road/driveway.
- When locating on a corner, place the hydrant 5-10 feet past the BCR (beginning curb return).
- Do not place in the bulb of a cul-de-sac.
- Place on the right side of the street if possible, based upon the normal response from the first-in fire station.
- Place on property lines between lots.
- If driveways are shown, try to place where there is the least impact to on-street parking.
- Keep 25-50 feet from any building if possible.
- Try to place where the road/driveway is level.
- If there is a slope behind the hydrant, require a retaining wall 3 feet back.
- Require concrete pads around hydrants.
- Watch grade level, walls and obstructions, anywhere you are considering placing a hydrant.
- When checking Mylar's you may do them at the counter as long as you have the original stamped hydrant location plan to check against.
- Any changes in location of fire hydrants shall be approved by the Fire Prevention Bureau prior to installation.
- Fire hydrants and water lines must be in the water purveyor's easement or within easements to the property owners that will benefit from the hydrant.
- Make sure you denote the hydrant type, size and number of outlets on the approved hydrant location plans.
- It is definitely preferable for a fire engine to pass the hydrant before the structure, i.e. a forward lay. Keep this in mind when placing hydrants.
- Remember: Each fire engine carries 700 feet of 3" and 700 feet of 4" hose for hydrant supply lines. You may stretch on your distance if it provides for better tactical use or to benefit a larger number of structures. (To save \$ is not a valid reason)